

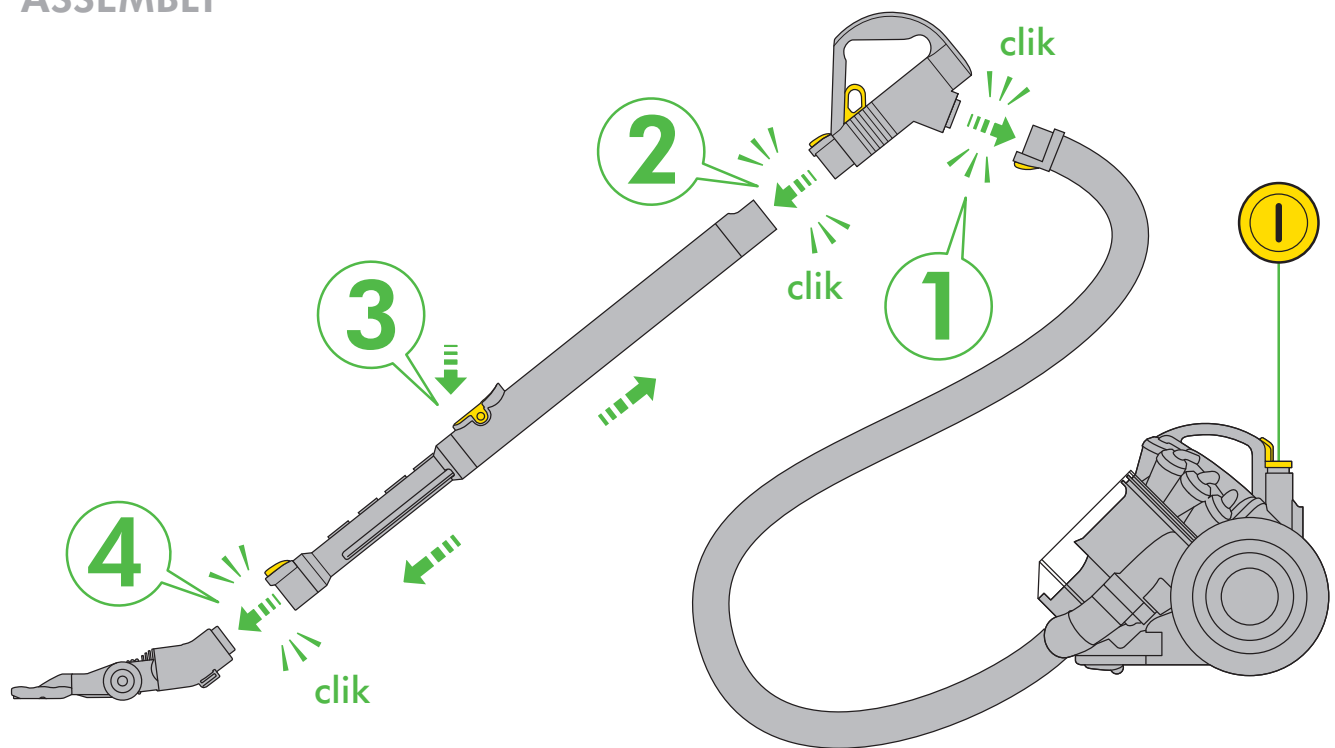

ASSEMBLY



**WASH FILTERS**  
Wash filters with cold water regularly or as required.

**REGISTER YOUR 2 YEAR GUARANTEE TODAY**

Phone icon:   
Envelope icon: 

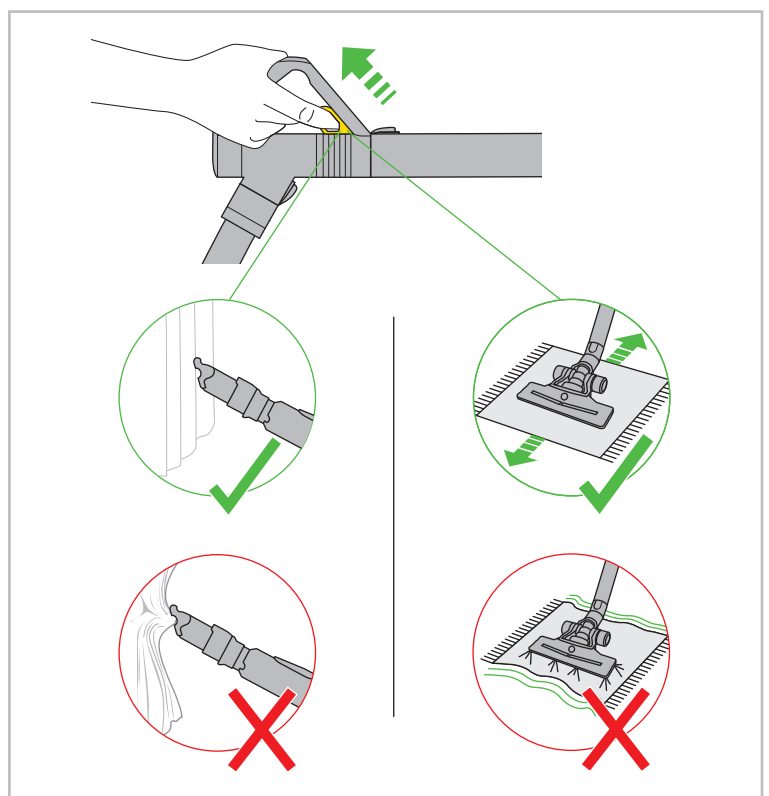

Your Dyson vacuum cleaner will be covered for parts and labour for 2 years from the date of purchase, subject to the terms of the guarantee.

If you have a query about your Dyson vacuum cleaner, call the Dyson Customer Care Helpline quoting the serial number and details of where/when you bought the vacuum cleaner. The serial number can be found on the main body of the vacuum cleaner behind the clear bin.

Most queries can be solved over the phone by one of our Dyson Customer Care Helpline staff.

Visit our website to register your full parts and labour guarantee online (Australia only).

[www.dyson.com.au/register](http://www.dyson.com.au/register)

Note your serial number for future reference

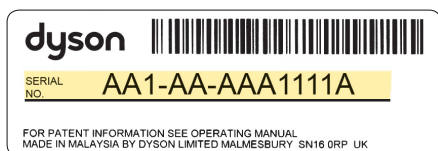

This illustration is for example purposes only.

### 3 EASY WAYS TO REGISTER YOUR 2 YEAR GUARANTEE



**REGISTER ONLINE**

Visit our website to register your full parts and labour guarantee online (Australia only).

[www.dyson.com.au/register](http://www.dyson.com.au/register)



**REGISTER BY PHONE**

Call our dedicated Helpline.

<b>AU</b>	<b>1800 239 766</b>
<b>NZ</b>	<b>0800 397 667</b>
<b>SG</b>	<b>7000 435 7546</b>
<b>ID</b>	<b>021 707 39766</b>



**REGISTER BY MAIL**

Complete and return the form to Dyson in the envelope supplied.

# IMPORTANT SAFETY INSTRUCTIONS

## READ ALL INSTRUCTIONS BEFORE USING THIS APPLIANCE

When using an electrical appliance, basic precautions should always be followed, including the following:

### WARNING

#### TO REDUCE THE RISK OF FIRE, ELECTRIC SHOCK, OR INJURY:

1. Do not leave the Dyson vacuum when plugged in. Unplug from socket when not in use and before servicing.
2. Do not use outdoors or on wet surfaces. Suitable for dry locations only. Do not use to pick up water.
3. Do not allow to be used as a toy. Close attention is necessary when used by or near children. Children should be supervised to ensure that they do not play with the Dyson vacuum.
4. This Dyson vacuum is not intended for use by young children or infirm persons with reduced physical, sensory or reasoning capabilities, or lack of experience and knowledge, unless they have been given supervision or instruction by a responsible person concerning use of the Dyson vacuum to ensure that they can use the Dyson vacuum safely.
5. Use only as described in this manual. Use only Dyson recommended accessories and replacement parts. Do not carry out any maintenance other than that shown in this manual, or advised by the Dyson Customer Care Helpline. Contact the Dyson Customer Care Helpline when service or repair is required. Do not disassemble the Dyson vacuum as incorrect reassembly may result in an electric shock or fire.
6. Do not use with a damaged cable or plug. If the Dyson vacuum is not working as it should, has been dropped, damaged, left outdoors, or dropped into water, do not use and contact the Dyson Customer Care Helpline. If the supply cable is damaged it must be replaced by Dyson, its service agent or similarly qualified person in order to avoid a hazard.
7. Do not pull or carry by cable, use cable as a handle, close a door on cable, or pull cable around sharp edges or corners. Do not run the Dyson vacuum over cable. Keep cable away from heated surfaces. To avoid a tripping hazard rewind the cable when not in use.
8. Always extend the cable to the red line but do not stretch or tug the cable.
9. Do not unplug by pulling on the cable. To unplug, grasp the plug, not the cable.
10. Do not handle the plug or Dyson vacuum with wet hands.
11. Do not put any object into openings. Do not use with any opening blocked; keep free of dust, lint, hair, and anything that may reduce airflow.
12. Keep hair, loose clothing, fingers, and all parts of body away from openings and moving parts, such as the brush bar. Do not point the hose, wand or tools at your eyes or ears or put them in your mouth.
13. Turn off all controls before unplugging.
14. Use extra care when cleaning on stairs. Do not work with the Dyson vacuum above you on the stairs.
15. Do not use to pick up flammable or combustible liquids, such as gasoline, or use in areas where they or their vapors may be present.
16. Do not pick up anything that is burning or smoking, such as cigarettes, matches, or hot ashes.
17. Do not use without the clear bin and filters in place.
18. Hold the plug when rewinding onto cable reel. Do not allow the plug to whip when rewinding.
19. The use of an extension cable is not recommended.

## READ AND SAVE THESE INSTRUCTIONS

THIS DYSON VACUUM IS INTENDED FOR HOUSEHOLD USE ONLY



Do not pull on the cable.



Do not store near heat sources.



Do not use near naked flame.



Do not run over the cable.



Do not pick up water or liquids.



Do not pick up burning objects.



Do not use above you on the stairs.

Storage

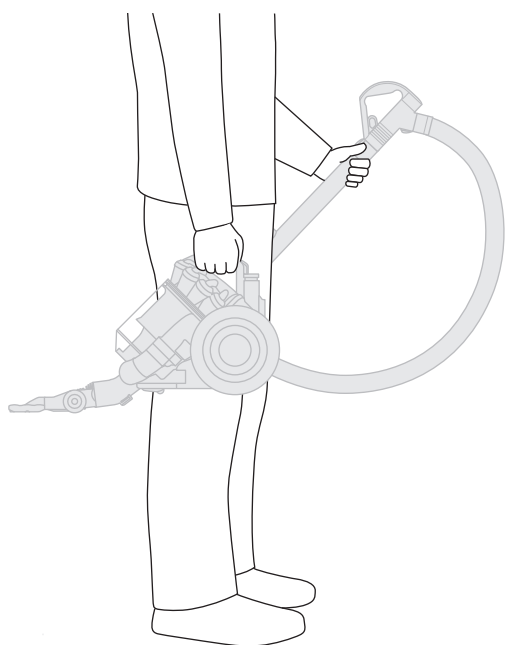
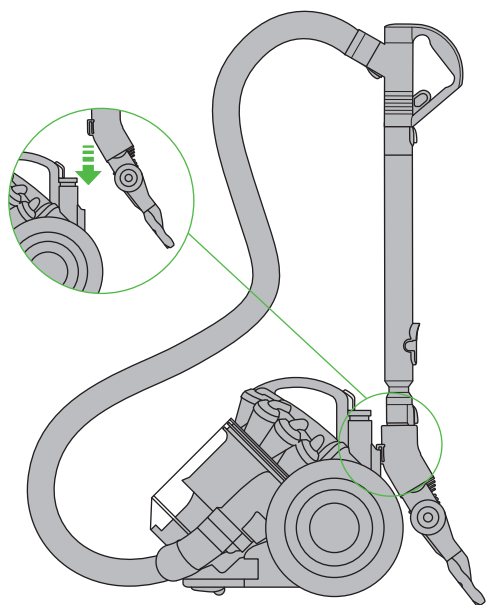

Suction release

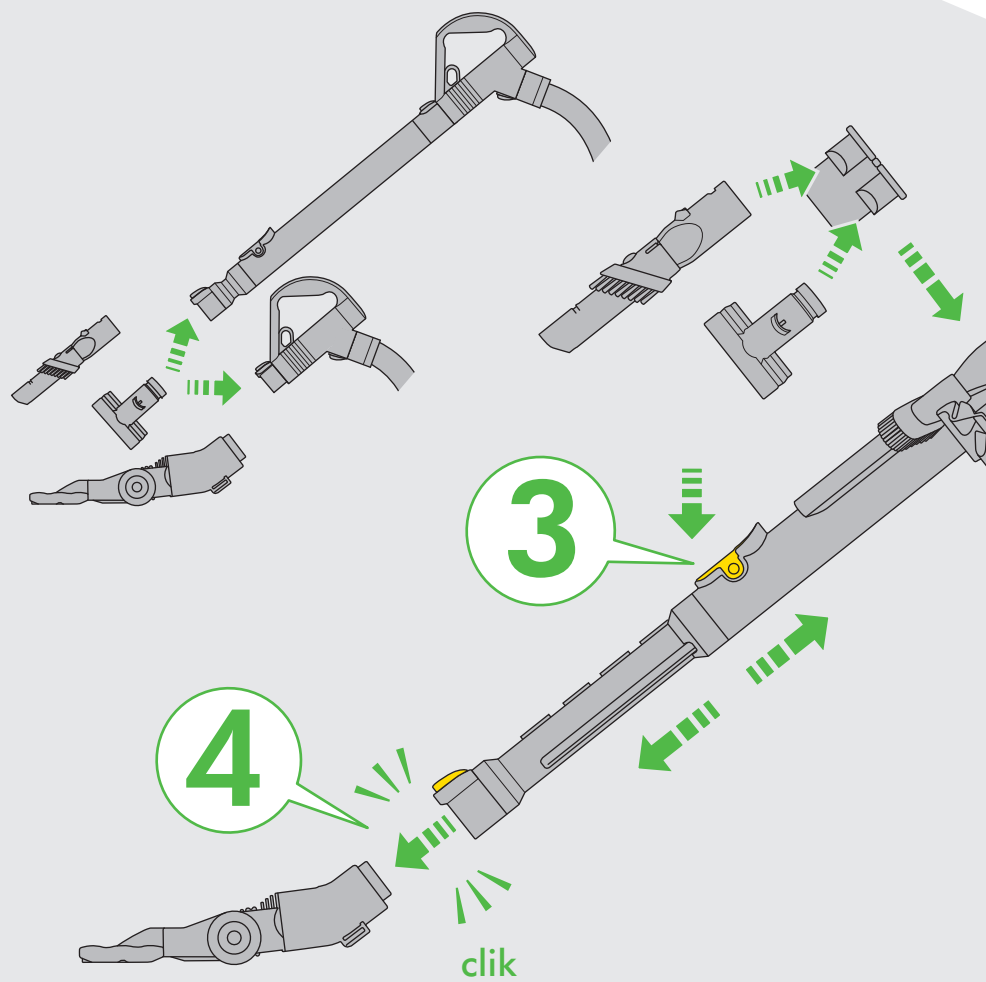
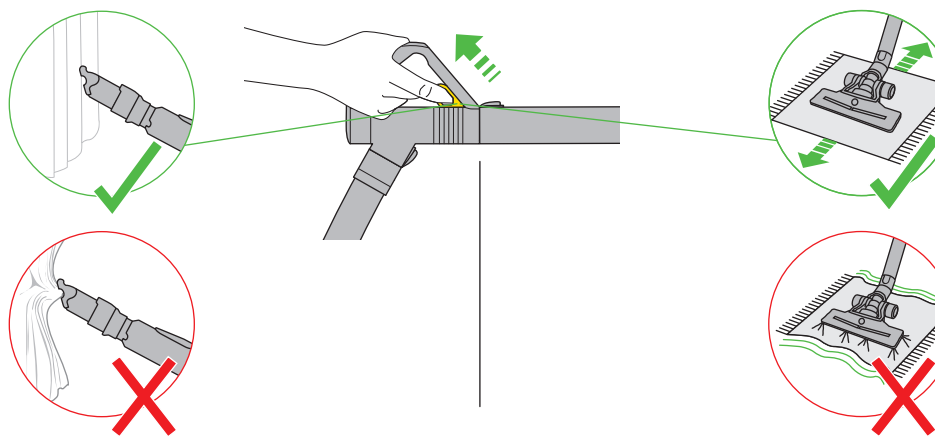

Blockages

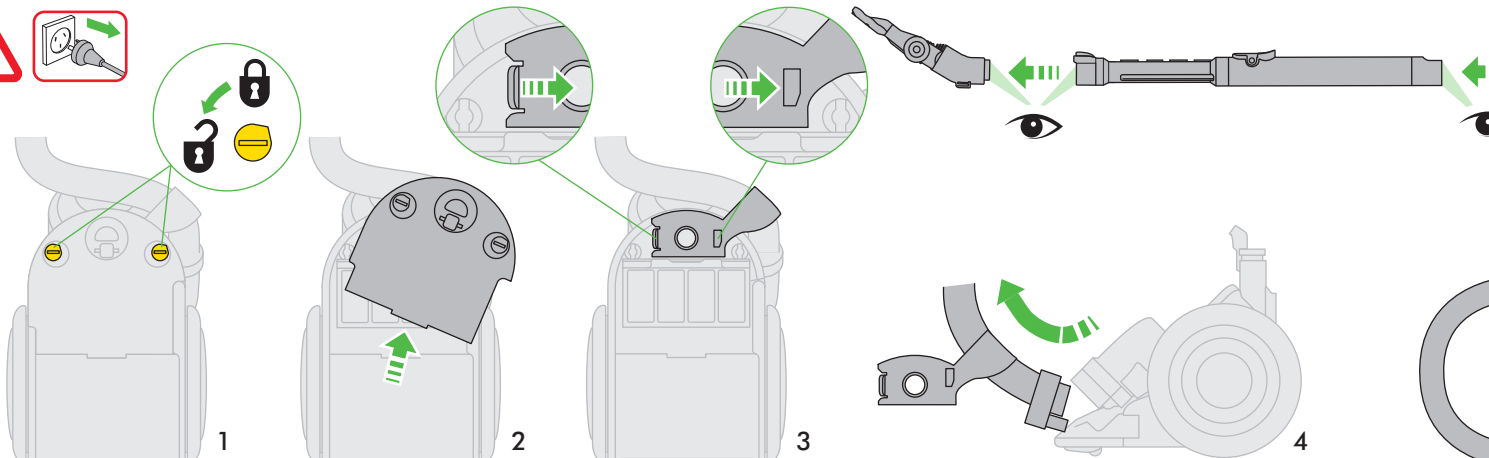

### Power & Cable

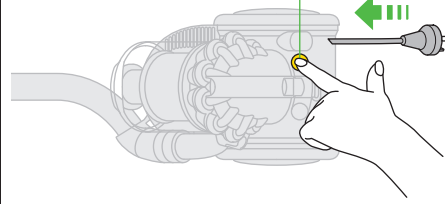
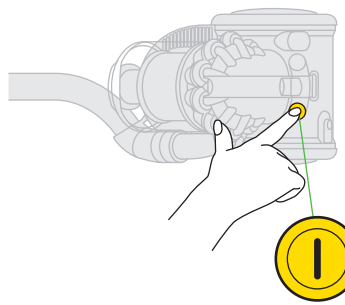

### Tools

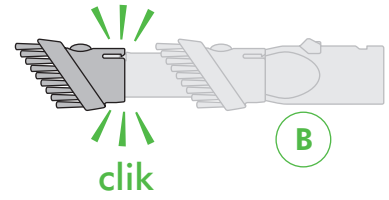
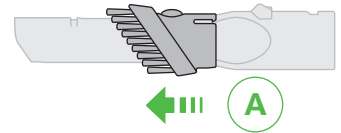

### Emptying

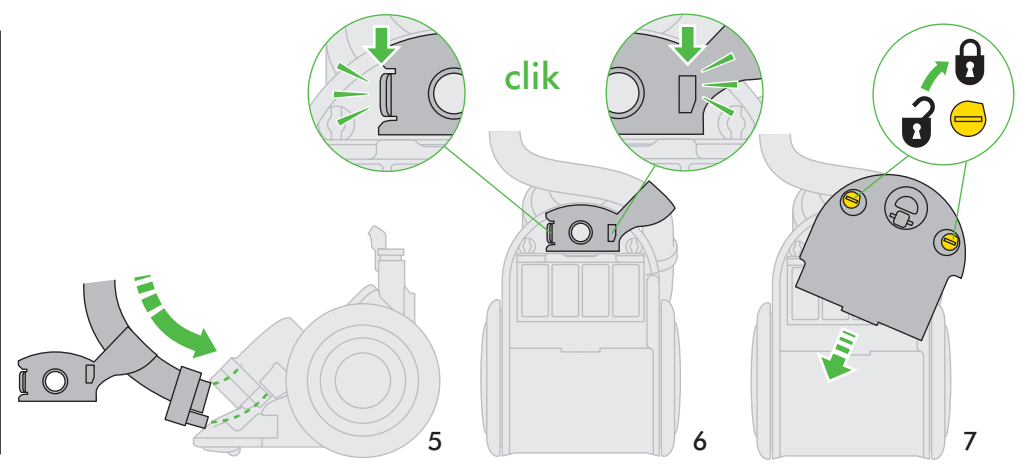
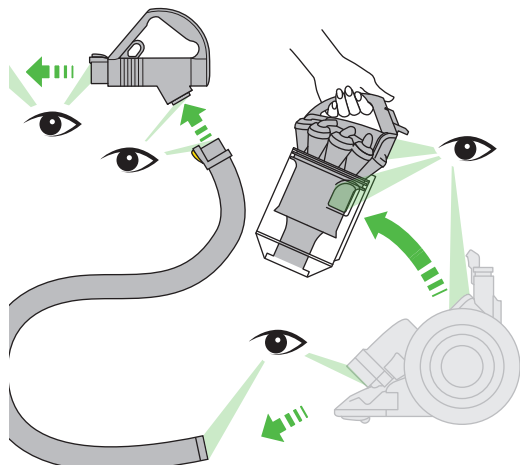
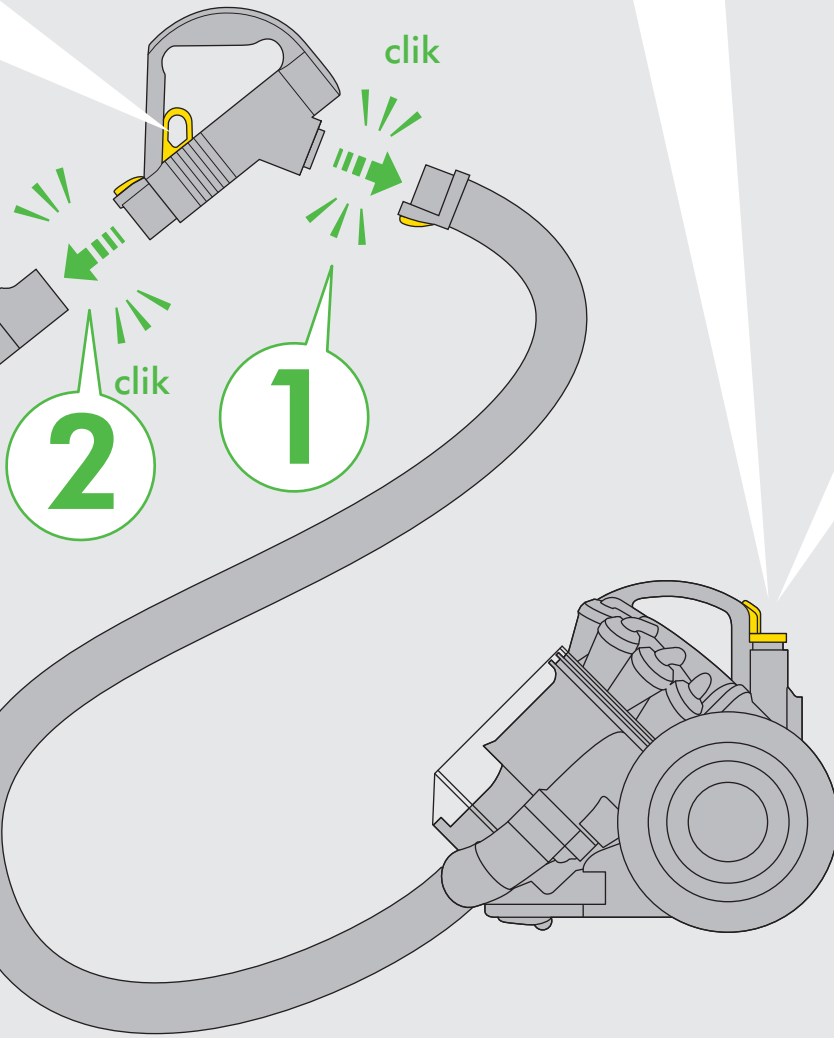
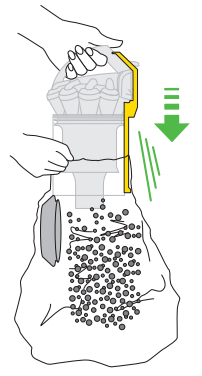

# IMPORTANT!

## WASH FILTERS



  **Filter A**

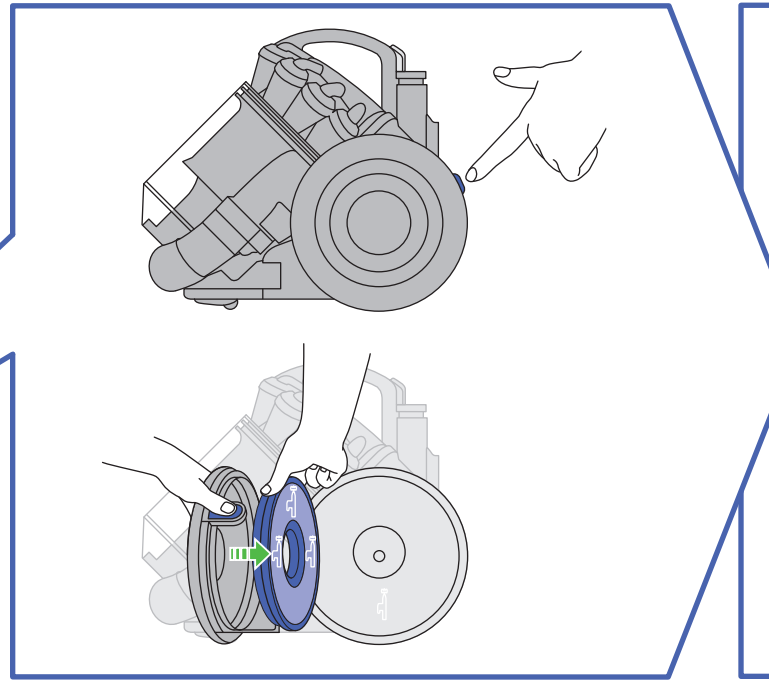

  **Filter B**

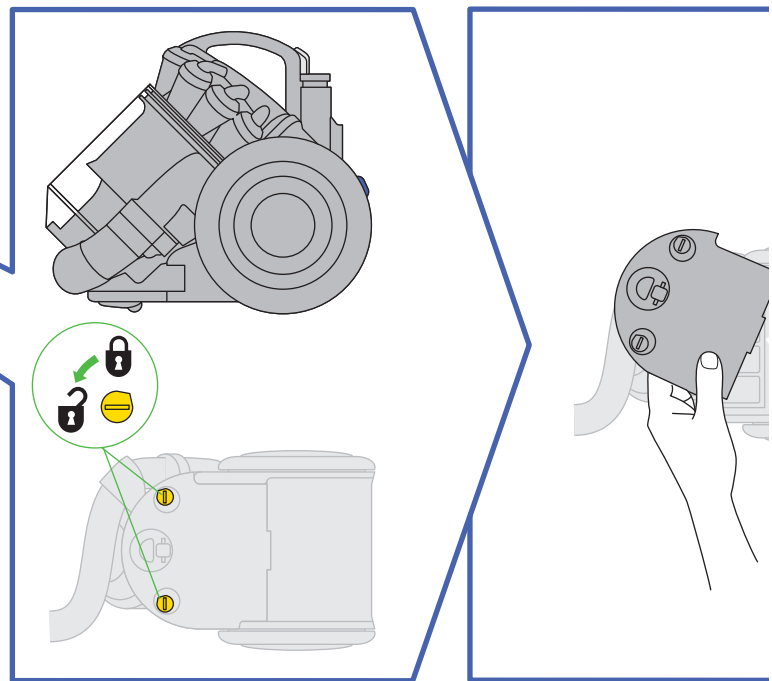

Wash filters with cold water regularly or as required.

Register for a filter wash reminder by email (Australia only);  
customercare@dyson.com.au

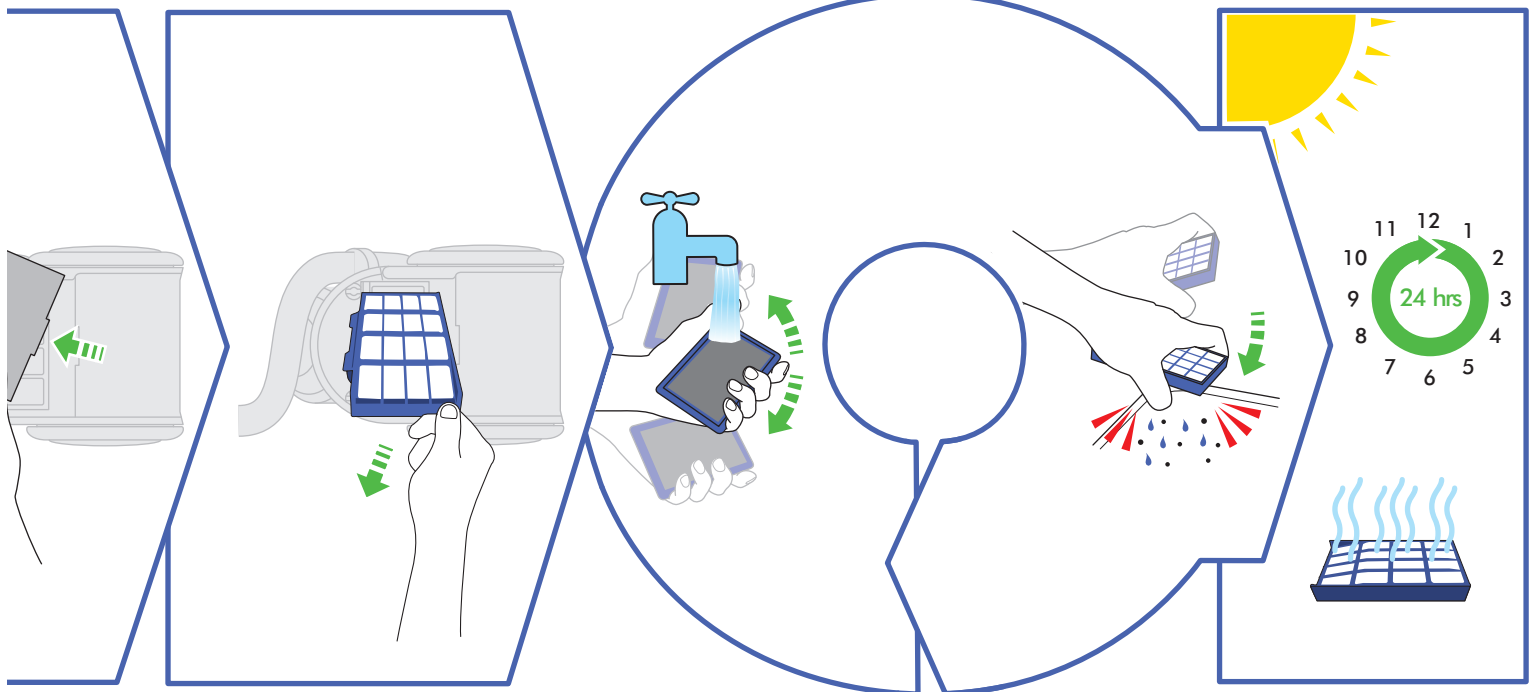
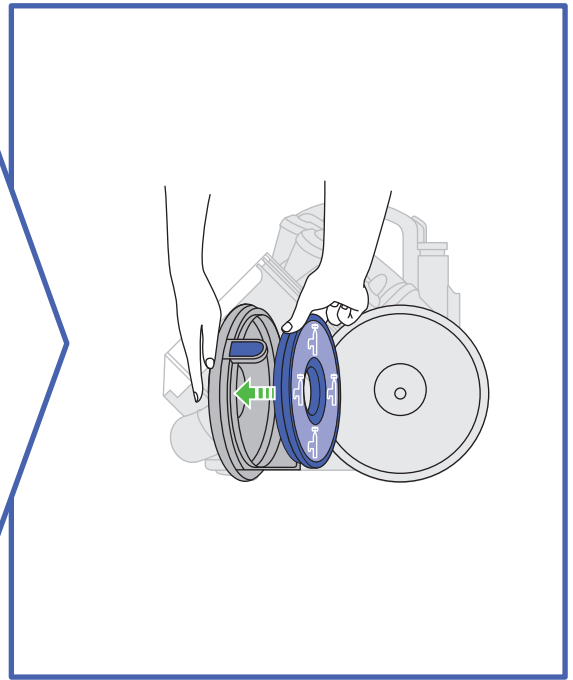
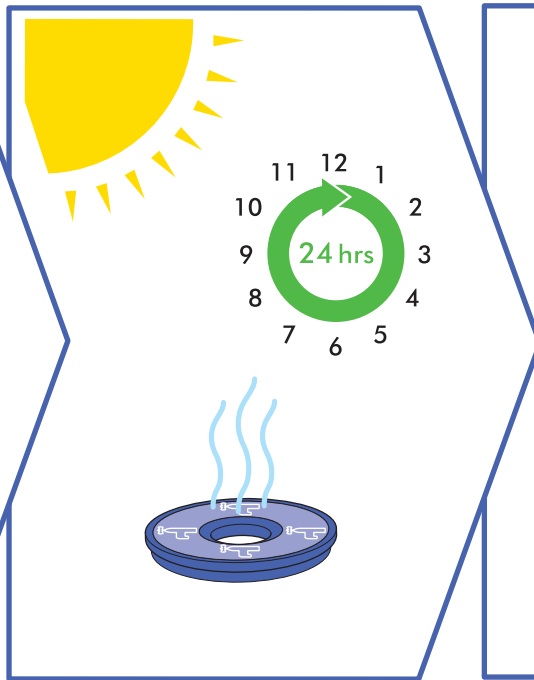
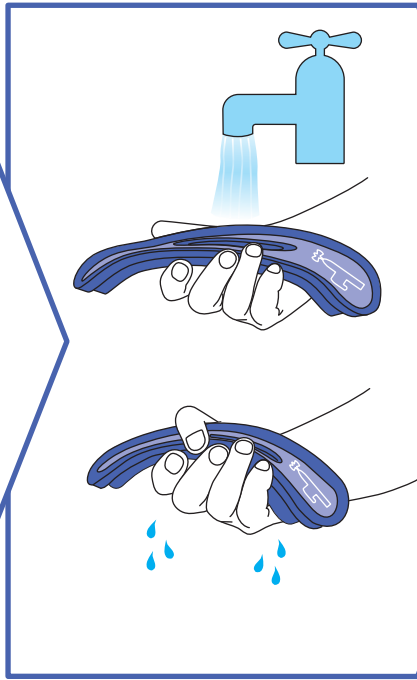

## USING YOUR DYSON VACUUM CLEANER

### ⚠ CAUTION:

- Do not allow the vacuum cleaner to be used by anyone who may not be able to operate it safely.
- The use of an extension cable is not recommended.
- Always switch 'OFF' and unplug before performing maintenance on your vacuum cleaner.
- Ensure the cyclone is secured to the vacuum cleaner. Do not press the cyclone release button or shake the vacuum cleaner while carrying or it could fall and cause injury.
- Store the vacuum cleaner indoors. Put the vacuum cleaner away after use with the cable coiled safely, to prevent tripping hazards.
- Do not use outdoors or on wet surfaces or to vacuum water or other liquids – electric shock could occur.
- Do not lubricate any parts, or carry out any maintenance or repair work other than that shown in this manual, or advised by the Dyson Customer Care Helpline.
- Do not use any lubricants, cleaning agents, polishes or air fresheners on any part of the Dyson vacuum.
- This Dyson vacuum is fitted with a thermal cut-out. If any part of the Dyson vacuum becomes blocked the machine may overheat and automatically shut off. If this happens, switch off and unplug the Dyson vacuum and allow to cool before attempting to check filters or for blockages. Clear any blockages before restarting.
- Store the vacuum cleaner indoors. Do not use or store this vacuum cleaner below 0°C (32°F). Ensure that the vacuum cleaner is at room temperature before operating.

### PLEASE NOTE:

- This vacuum cleaner is intended for domestic use only. Fine dust such as plaster dust or flour should only be vacuumed in very small amounts.
- Do not use the vacuum cleaner to pick up sharp hard objects, small toys, pins, paper clips, etc. They may damage the vacuum cleaner.
- If used in a garage, care should be taken to wipe the soleplate and wheels with a dry cloth after vacuuming to clean off any sand, dirt, or pebbles that could damage delicate floors.
- When vacuuming, certain carpets may generate small static charges in the clear bin. These are entirely harmless and are not associated with the mains supply. To minimise any effect from this, do not put your hand or insert any object into the clear bin unless you have first emptied it and rinsed it out with cold water. (See 'Cleaning the clear bin' section on page 8).
- Do not use or store this vacuum cleaner below 0°C. Ensure that the vacuum cleaner is at room temperature before operating.

## EMPTYING THE CLEAR BIN

### ⚠ CAUTION:

- Switch 'OFF' the vacuum cleaner and unplug before emptying the clear bin.
- Empty as soon as the dirt reaches the level of the MAX mark – do not overfill.
- To remove the clear bin from the vacuum cleaner, press the grey button at the rear of cyclone carrying handle. To release the dirt, press the red bin release button. Emptying into a bag is recommended for people with asthma and allergies.
- To minimise dust/allergen contact when emptying, encase the clear bin tightly in a plastic bag and empty. Remove the clear bin carefully and seal bag tightly, dispose as normal.
- Do not use the vacuum cleaner without the clear bin in place.

## CLEANING THE CLEAR BIN

### ⚠ CAUTION:

- To remove the cyclone unit from the clear bin press the red bin release button. This exposes a small silver button behind the red opening mechanism. Press the silver button and separate the cyclone unit from the clear bin.
- Clean the clear bin with cold water only.
- Ensure the clear bin is completely dry before replacing.

### PLEASE NOTE:

- Do not use detergents, polishes or air fresheners to clean the clear bin.
- Do not put clear bin in a dishwasher.
- Clean the shroud with a cloth or dry brush to remove lint and dust.

## WASHING YOUR FILTERS

### ⚠ CAUTION:

- Switch 'OFF' and unplug the vacuum cleaner before removing the filters.
- Ensure filters are completely dry before refitting to the vacuum cleaner.

### PLEASE NOTE:

- This machine has two filters, located as shown. It is important to check your filters and wash with cold water regularly, or as required, to maintain performance. Filter B should be rinsed and tapped out until the water runs clean, then tapped out again to ensure all excess water is removed.
- After washing please leave for 24 hours to dry completely.
- The filters may require more frequent washing if vacuuming fine dust.
- Do not use detergents to clean the filters.
- Do not put the filters in a dishwasher, washing machine, tumble dryer, oven, microwave or near a naked flame.

## LOOKING FOR BLOCKAGES

### ⚠ CAUTION:

- Switch 'OFF' and unplug the vacuum cleaner before checking for blockages. Failure to do so could result in personal injury.
- Beware of sharp objects when clearing blockages.
- Refit all parts of the vacuum cleaner securely before using.

### PLEASE NOTE:

- Clearing blockages is not covered by your vacuum cleaner's limited guarantee.
- This vacuum cleaner is fitted with an automatically resetting thermal cut-out. If any part of the vacuum cleaner becomes blocked, it may overheat and automatically cut-out. Switch 'OFF' and unplug the vacuum cleaner and leave to cool down for 1-2 hours before checking filters or for blockages.
- Large items may block the tools or wand inlet, if this happens switch the vacuum cleaner off and unplug the vacuum cleaner before removing the blockage. Do not operate the wand release catch.

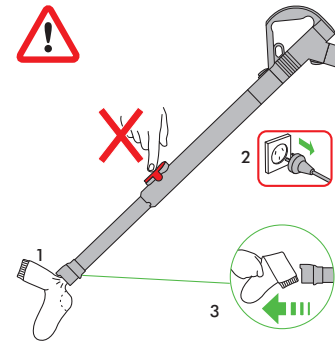

## DISPOSAL INFORMATION

Dyson products are made from high grade recyclable materials. Please dispose of this product responsibly and recycle where possible.

When your Dyson vacuum cleaner reaches the end of its life, we are responsible for its safe disposal. You can send your old Dyson vacuum cleaner back to us (at our cost) and we will organise for it to be recycled.\*

\*Please note that not all parts are recyclable. Recycling of parts is subject to the capabilities of 3rd party suppliers. Available in Australia only.

### Simply:

1. Box up your old Dyson vacuum cleaner
2. Take your package to your local post office and send to the address below:

Dyson We Recycle  
Reply Paid 83215  
Dyson Service Centre  
Unit 6 & 7, 7-11 Parraweena Rd  
Taren Point, NSW 2229.



## 2 YEAR DYSON GUARANTEE TERMS AND CONDITIONS

Terms and conditions of your Dyson 2 year guarantee.

- The guarantee becomes effective from the date of purchase.
- All work will be carried out by Dyson Appliances (Aust) Pty Ltd, Avery Robinson Ltd (NZ), Singapore's authorised agent - Service @Home Pte Ltd., Indonesia's authorised agent - PT Higienis Indonesia or their authorised agents.
- Any parts replaced will become the property of Dyson Appliances (Aust) Pty Ltd., Avery Robinson Ltd (NZ), Dyson Singapore Pte Ltd., PT Higienis Indonesia.
- The repair and replacement of your vacuum cleaner under guarantee will not extend the period of guarantee.
- The guarantee provides benefits which are additional to and do not affect your statutory rights as a consumer.
- You must provide proof of purchase before any work can be carried out on your vacuum cleaner. Without this proof, any work carried out will be chargeable. Please keep your receipt.

### WHAT IS COVERED

The repair or replacement of your vacuum cleaner if your vacuum cleaner is found to be defective due to faulty materials, workmanship or function within 2 years of purchase (if any part is no longer available or out of manufacture, Dyson will replace it with a functional replacement part).

### WHAT IS NOT COVERED

Dyson shall not be liable for costs of repair or replacement of a product incurred as a result of:

- Normal wear and tear (e.g. fuse, belt, brush bar, batteries etc).
- Industrial use of the vacuum cleaner such as vacuuming gyprock dust or builders dust may void your guarantee.
- Accidental damage, faults caused by negligent use or care, neglect, careless operation or handling of the vacuum cleaner which is not in accordance with this Dyson Operating Manual.
- Blockages – please refer to this Dyson Operating Manual for details of how to unblock your vacuum cleaner.
- Use of the vacuum cleaner for anything other than normal domestic household purposes in the country of purchase.
- Use of parts not assembled or installed in accordance with the instructions of Dyson.
- Use of parts and accessories other than those produced or recommended by Dyson.
- Damage from external sources such as transit, weather, electrical outages or power surges.
- Failures caused by circumstances outside Dyson's control.
- Repairs or alterations carried out by parties other than Dyson or its authorised agents.

If you are in any doubt as to what is covered by your guarantee, please call the Dyson Customer Care Helpline on:

Australia 1800 239 766  
New Zealand 0800 397 667  
Singapore 7000 435 7546  
Indonesia 021 707 39766

Remember: Always disconnect plug from mains before inspecting for problems.

- If your vacuum cleaner will not operate, first check: mains socket has electricity supply and the plug is properly inserted into the socket.
- Sucking up certain items such as stockings, clippings of cloth, sizeable pieces of paper etc may block the hose or ducts. Should a blockage occur, first disconnect the vacuum cleaner from the electricity supply and refer to the 'Looking for blockages' section in this Dyson Operating Manual (see pages 4, 5 and 8).
- Never pick up hot cinders or lit cigarette ends.
- Do not attempt to pick up water with your Dyson vacuum cleaner. It has not been designed as a wet pick-up cleaner.

### REGISTERING YOUR GUARANTEE

To help us ensure you receive prompt and efficient service, please register as a Dyson vacuum cleaner owner. There are three ways to do this:

- Online (Australia only) at [www.dyson.com.au/register](http://www.dyson.com.au/register)
  - By calling the Dyson Customer Care Helpline.
  - By completing and returning the enclosed form to us by mail.
- This will confirm ownership of your Dyson vacuum cleaner in the event of an insurance loss, and enable us to contact you if necessary.

## DYSON CUSTOMER CARE

THANK YOU FOR CHOOSING TO BUY A DYSON VACUUM CLEANER

If you have a query about your Dyson vacuum cleaner, call the Dyson Customer Care Helpline and quote your serial number, or contact us via the website. The serial number can be found on the main body of the vacuum cleaner behind the clear bin.

Most queries can be solved over the phone by one of our Dyson Customer Care Helpline staff.

If your Dyson vacuum cleaner needs a service, call the Dyson Customer Care Helpline so we can discuss the available options.

If your vacuum cleaner is under guarantee and the repair is covered, it will be repaired at no cost.

### DYSON CUSTOMER CARE DETAILS

If there are any queries, please call the Dyson Customer Care Helpline.

AU: 1800 239 766

(Mon-Fri 8:00am to 6:00pm EST, Sat-Sun 8:30am to 4:00pm EST)

[www.dyson.com.au](http://www.dyson.com.au)

NZ: 0800 397 667

(Mon-Fri 8:30am to 5:00pm)

[www.dyson.co.nz](http://www.dyson.co.nz)

SG: 7000 435 7546

(Mon-Fri 9:00am to 6:00pm)

[www.dyson.com.sg](http://www.dyson.com.sg)

ID: 021 707 39766

(Mon-Fri 9:00am to 5:00pm)

[www.dyson.co.id](http://www.dyson.co.id)

### ABOUT YOUR PRIVACY

Dyson may use this information for future marketing and research purposes (including sending commercial electronic messages) and may disclose it to third parties for the purposes of providing the services you have requested or to our business partners or professional advisers. If you wish to access your personal information or see our full privacy policy, please contact us at [customercare@dyson.com.au](mailto:customercare@dyson.com.au)

### DISPOSAL INFORMATION

Dyson products are made from high grade recyclable materials. Please dispose of this product responsibly and recycle where possible.

When your Dyson vacuum cleaner reaches the end of its life, we are responsible for its safe disposal. You can send your old Dyson vacuum cleaner back to us (at our cost) and we will organise for it to be recycled.\*

\*Please note that not all parts are recyclable. Recycling of parts is subject to the capabilities of 3rd party suppliers. Available in Australia only.

Simply:

1. Box up your old Dyson vacuum cleaner
2. Take your package to your local post office and send to the address below:  
Dyson We Recycle  
Reply Paid 83215  
Dyson Service Centre  
Unit 6 & 7, 7-11 Parraweena Rd  
Taren Point, NSW 2229.

### PRODUCT INFORMATION

Maximum product weight 5.26kg.

Please note: Small details may vary from those shown.

# IMPORTANT!

## WASH FILTERS

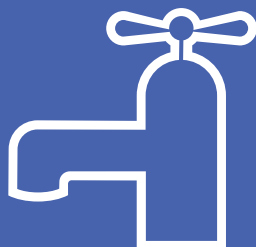

Wash your filters with cold water regularly or as required.

Register for a filter wash reminder by email (Australia only):  
[customercare@dyson.com.au](mailto:customercare@dyson.com.au)



### Dyson Customer Care

If you have a question about your Dyson vacuum cleaner, call the Dyson Customer Care Helpline with your serial number and details of where and when you bought the vacuum cleaner, or contact us via the Dyson website. The serial number can be found on the main body of the vacuum cleaner behind the clear bin.

**AU Dyson Customer Care**  
[customercare@dyson.com.au](mailto:customercare@dyson.com.au)  
**1800 239 766**  
Dyson Appliances (Aust) Pty Ltd.,  
PO Box 2175,  
Taren Point, NSW 2229,  
Australia  
[www.dyson.com.au](http://www.dyson.com.au)

**NZ Dyson Customer Care**  
[dyson@averyrobinson.co.nz](mailto:dyson@averyrobinson.co.nz)  
**0800 397 667**  
Avery Robinson Ltd.,  
Unit F, 151D Marua Road,  
Ellerslie, Auckland 1051,  
New Zealand  
[www.dyson.co.nz](http://www.dyson.co.nz)

**SG Dyson Customer Care**  
[singapore@dyson.com](mailto:singapore@dyson.com)  
**7000 435 7546**  
Service @ Home Pte. Ltd.,  
2 Leng Kee Road, #04-09A Thye Hong Centre,  
Singapore 159086  
[www.dyson.com.sg](http://www.dyson.com.sg)

**ID Dyson Customer Care**  
[service@higienis.com](mailto:service@higienis.com)  
**021 707 39766**  
PT. Higienis Indonesia  
Permata Plaza Top Floor, TF-04,  
Jl. M. H. Thamrin Kav. 57,  
Jakarta 10350  
Indonesia  
[www.dyson.co.id](http://www.dyson.co.id)

Please take a few moments to answer our questions.  
They will help us develop new products for the future.

- 1 This vacuum cleaner is...
- My first vacuum cleaner
  - A replacement vacuum cleaner
  - An additional vacuum cleaner
- 2 Which brand of cleaner are you replacing or adding to?
- |                                 |  |
|---------------------------------|--|
| <input type="checkbox"/> Dyson  | <input type="checkbox"/> Electrolux            |
| <input type="checkbox"/> Hoover | <input type="checkbox"/> LG                    |
| <input type="checkbox"/> Miele  | <input type="checkbox"/> Nilfisk               |
| <input type="checkbox"/> Vax    | <input type="checkbox"/> Wertheim              |
| <input type="checkbox"/> Volta  | <input type="checkbox"/> Other, please specify |
- 3 Why did you choose to buy a Dyson vacuum cleaner?  
(Please rank in order, 1-5. 1 being the most important).
- Dyson reputation
  - Good for pet hair pick-up
  - No loss of suction
  - Previous experience of Dyson
  - HEPA filter/benefit for asthma and allergy sufferers
  - Features
  - Price/special offer
  - Wanted a bagless cleaner
  - Compact and easy to store
  - Store staff recommendation
  - Picks up more dust than others
  - Latest model/technology
  - Reliability/quality
  - Friend/family recommendation
  - Other
- 4 Where did you first hear about Dyson?
- From friends and family
  - Saw it on the internet
  - From TV/a magazine advert
  - Saw it in a store catalogue
  - Saw it in a store
  - Recommended by salesperson
- 5 Where did you look for additional information?
- Visit brand website
  - Look at online reviews and forums
  - Talk to retail staff
  - Pick up retail catalogue
  - Didn't do any additional research
- 6 Do you own other Dyson products?
- Handheld
  - Fan
  - No
- 7 What is your average household income?
- Less than \$45,000
  - Between \$45,000 – \$74,999
  - Between \$75,000 – \$100,000
  - Over \$100,000
- 8 Do you have any household pets?
- Dog
  - Cat
  - No
  - Other
- 9 Does anyone in your household suffer from any of the following?
- Asthma
  - Allergies
  - No
- 10 To which age group do you belong?
- |                                  |                                  |
|----------------------------------|----------------------------------|
| <input type="checkbox"/> 16 – 24 | <input type="checkbox"/> 25 – 34 |
| <input type="checkbox"/> 35 – 44 | <input type="checkbox"/> 45 – 54 |
| <input type="checkbox"/> 55 – 64 | <input type="checkbox"/> 65+     |
- 11 Would you recommend a Dyson vacuum cleaner to your family and friends?
- Yes
  - No
- 12 Do you have children?
- |   |   |
|---|---|
| <input type="checkbox"/> Pre-school     | <input type="checkbox"/> Aged 5-17 years            |
| <input type="checkbox"/> Aged +17 years | <input type="checkbox"/> Children no longer at home |
| <input type="checkbox"/> Pregnant       | <input type="checkbox"/> No children                |

THANK YOU FOR YOUR TIME



# dyson GUARANTEE FORM

2 year guarantee – plus option to extend to 5 years.

## Section 1: Dyson 2 year guarantee

Please complete Section 1 to register as a Dyson machine owner, and return it in the envelope provided. Alternatively, register online (Australia only).

Serial number		
Date of purchase	<input type="text"/> / <input type="text"/> / <input type="text"/>	Country of purchase AU <input type="checkbox"/> NZ <input type="checkbox"/> SG <input type="checkbox"/> ID <input type="checkbox"/>
Store of purchase		
<input type="text"/>		
Did you purchase an extended warranty from the retailer?	Yes <input type="checkbox"/>	No <input type="checkbox"/>
If yes, for what additional period?	1 year <input type="checkbox"/>	2 years <input type="checkbox"/> 3 years <input type="checkbox"/>
Title	First name	Surname
<input type="text"/>	<input type="text"/>	<input type="text"/>
Address		
<input type="text"/>		
<input type="text"/>		
<input type="text"/>		
<input type="text"/>		
Postcode		
<input type="text"/>		
email	Contact number	
<input type="text"/>	<input type="text"/>	
<b>Privacy Act</b>		
Dyson may use this information for future marketing and research purposes (including sending commercial electronic messages) and may disclose it to third parties for the purposes of providing the services you have requested or to our business partners or professional advisers. If you wish to access your personal information or see our full privacy policy, please contact us at <a href="mailto:customer@dyson.com.au">customer@dyson.com.au</a>		
If you do not wish to receive marketing information by these methods from Dyson please tick this box. <input type="checkbox"/>		

**REGISTER ONLINE**  
Visit our website to register your full parts and labour 2 year guarantee.  
[www.dyson.com.au/register](http://www.dyson.com.au/register)

**REGISTER BY MAIL**  
Complete and return the form to Dyson in the envelope supplied.

**REGISTER BY PHONE**  
Call our dedicated Helpline

AU 1800 239 766 NZ 0800 397 667  
SG 7000 435 7546 ID 021 707 39766

## Section 2: Dyson 2+3 year guarantee

Increase your cover to 5 years when you purchase an extended guarantee from Dyson (Australia only). This option is just AU\$59.00. Dyson is committed to providing the best Aftersales Service, which is why we offer the option to extend your 2 year guarantee to 5 years. The Dyson extended guarantee is underwritten by Dyson Appliances (Aust) Pty Ltd. To purchase, just complete the fields below. Send both sections to us, together with your cheque/money order or credit card details, within 2 years of your vacuum cleaner purchase. Offer to purchase the extended guarantee is only available within 2 years of customers purchasing their vacuum cleaner. Offer not available to customers who have purchased an extended warranty from a retailer.

Cheque/money order made payable to: Dyson Appliances.

Credit card  Mastercard  Visa

Card Number  Expiry Date M/M  Y/Y

**Declaration**

I hereby apply for the Dyson vacuum cleaner extended guarantee in accordance with the terms and conditions of your plan. I confirm the vacuum cleaner is in good working order and used for domestic purposes only and declare that the details on this proposal are true and complete to the best of my knowledge and belief.

Signature  Date  /  /

WARNING Any false statement may render this plan invalid